

# 502F, 503F, 504F, 505F, 506F, 507F, 508F, & 509F

## Trim

### Installation Instructions

**ACCENTRA**  
**ASSA ABLOY**

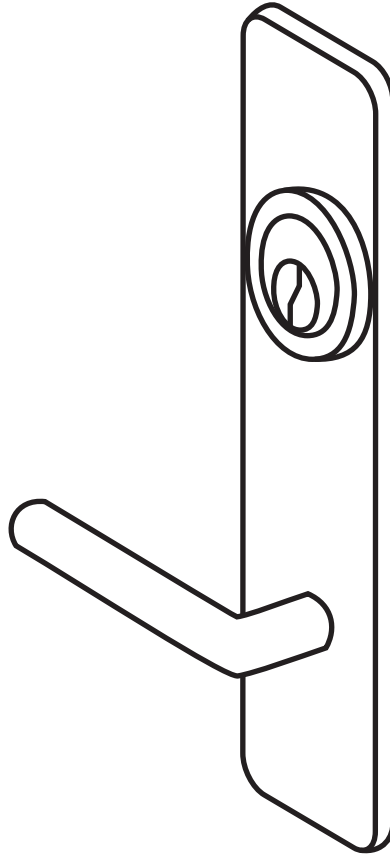

#### **⚠ WARNING**

This product can expose you to lead which is known to the state of California to cause cancer and birth defects or other reproductive harm. For more information go to [www.P65warnings.ca.gov](http://www.P65warnings.ca.gov).

#### **⚠ WARNING**

Attention Installer: Any retrofit or other field modification to a fire rated opening can potentially impact the fire rating of the opening, and ASSA ABLOY makes no representations or warranties concerning what such impact may be in any specific situation. When retrofitting any portion of an existing fire-rated opening, or specifying and installing a new fire-rated opening, please consult with a code specialist or local code official (Authority Having Jurisdiction) to ensure compliance with all applicable codes and ratings.

1-855-557-5078 Ext. 2 • [www.accentra-assaabloy.com](http://www.accentra-assaabloy.com)

80-8470-0502-000 04/24

**ACCENTRA**

**ASSA ABLOY**

**502F, 503F, 504F, 505F, 506F, 507F, 508F, & 509F**

**Trim**

**Installation Instructions**

80-8470-0502-000 04/24

Experience a safer  
and more open world

1-855-577-5078 Ext. 2 • [www.accentra-assaabloy.com](http://www.accentra-assaabloy.com)

Copyright © 2013, 2023, 2024, ASSA ABLOY ACCENTRA™ Access and Egress Hardware Group, Inc. All rights reserved. Reproduction in whole or in part without the express written permission of ASSA ABLOY Access and Egress Hardware Group, Inc. is prohibited.

**1. Assembly Instructions**

Figure 1

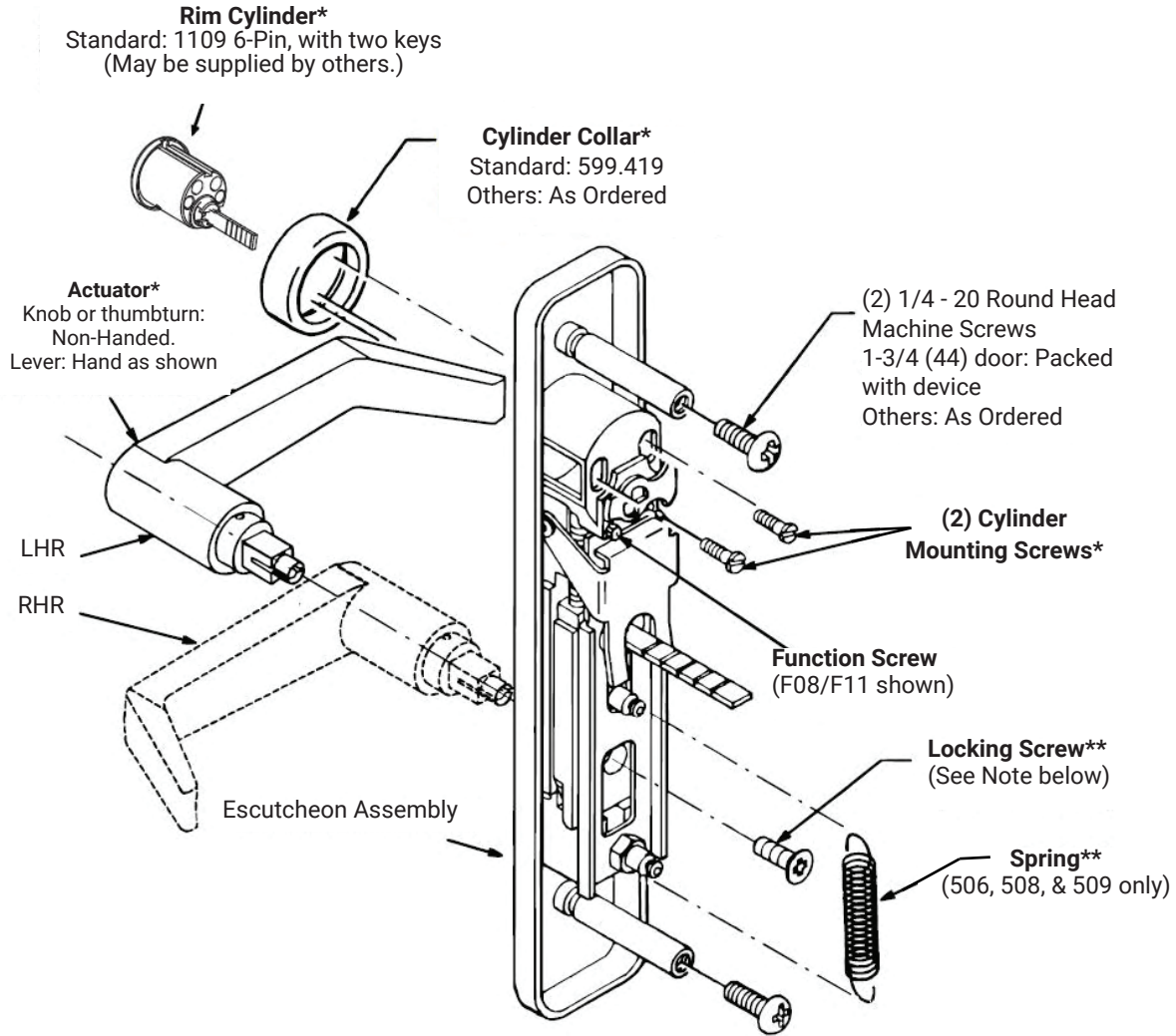

**Assembly Instructions**

Trim	Requirement
504F, 505F, 507F	None
506F, 508F, 509F	Check Hand (See Figure 1). To REVERSE HAND, remove and reassemble components marked (**), as shown.
502F, 503F	Assemble Cylinder (See instructions on page 6)

**NOTE:** When Locking Screw patch becomes worn or damaged, replace screw or use thread locking compound (available at auto parts stores).

**NOTE:** Knob and thumbturn trim are not handed. Lever trim is field reversible. In door pairs, knobs must be no less than 3-3/4" (95cm) on centers.

### 2. Installation Instructions

- A. Check box contents. (See page 3)
- B. Carry "Centerline of Device Mounting Holes" to outside door face. Follow steps A and B below.

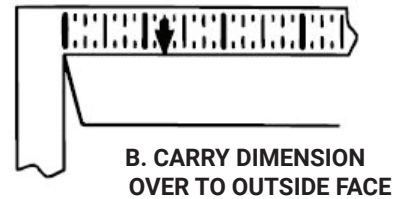
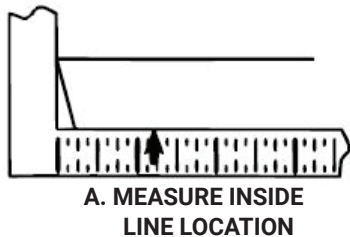

- C. Carry horizontal "Centerline of Device" from inside to outside door face.
- D. Align trim template and tape to door outside face.



**Caution:** Office copiers and facsimile machines may change the size of a drawing and make the template inaccurate to use as a door marker. If this is not the original template packed with the trim, use only the dimensions written on the template to locate the holes and cutout on the door. Do not use the template as a door marker.

- E. Spot holes and prepare door for trim.
- F. Mount trim to door. Fasten finger tight with two screws packed with device. (See Figure 2)
- G. With trim unlocked (tailpiece turning when lever is depressed or knob thumbturn is rotated), cut trim tailpiece as shown in Figure 3.
- H. Seat device so that trim tailpiece penetrates cam slot, as shown in Figure 3.
- I. Continue as shown in device instructions.

**Figure 2**

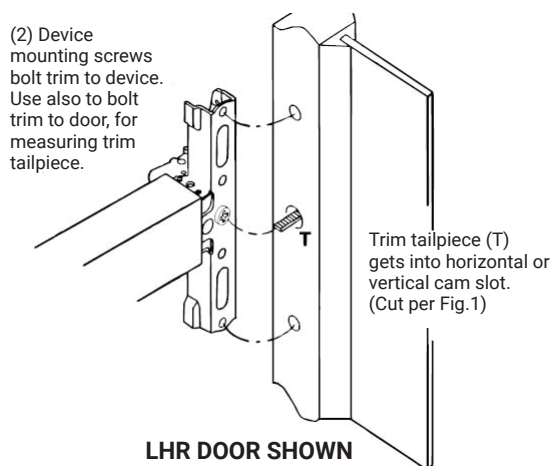

**Figure 3**

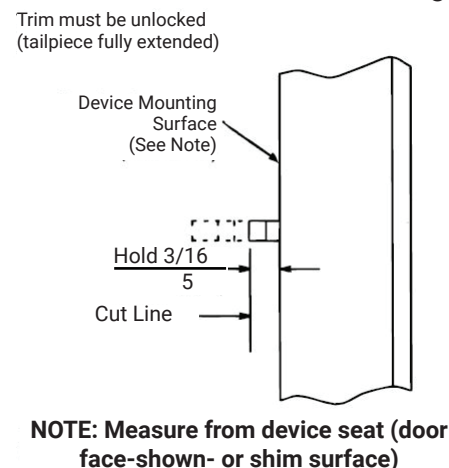

# 502F, 503F, 504F, 505F, 506F, 507F, 508F, & 509F

## Trim

### Installation Instructions

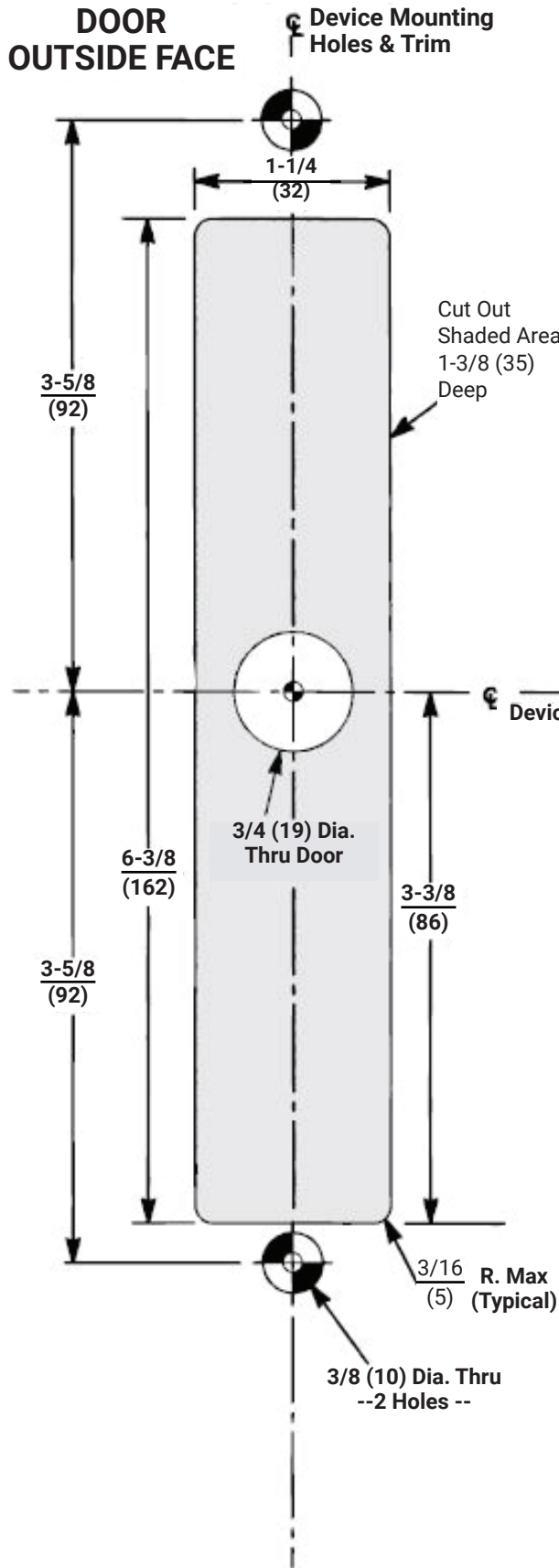

**Passage: Knob/Lever/Thumbturn always active**

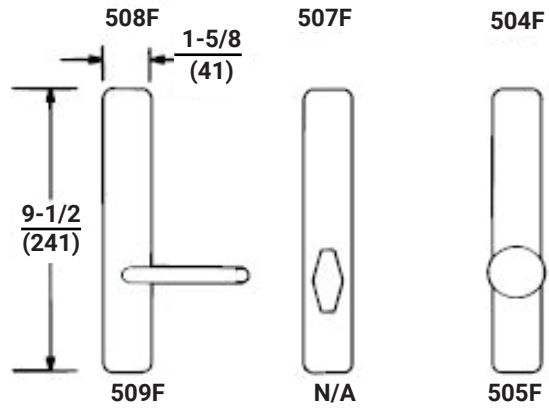

**Dummy Trim** (Knob/Lever rotates without engaging devices).

**F02**, push-pull door while device is dogged (not for fire devices).

**Cylinder Locks/Unlocks Knob, Lever or Thumbturn.**

**F08 or F11** (as packed), key removable locked or unlocked

**F09 or F12** (field conversion), key removable when trim is locked.

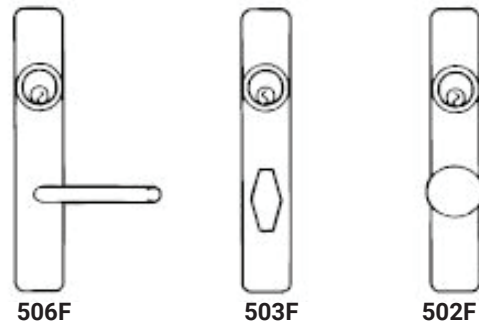

CUT LINE



### 3. Cylinder Assembly

A. Check cylinder components. See chart below. Non-standard cylinder collars and mounting screws must be supplied with optional cylinders.

CYLINDER COLLAR APPLICATIONS							
	<table border="1"> <thead> <tr> <th>Collar Number</th> <th>Collar Dim. "H"</th> </tr> </thead> <tbody> <tr> <td>599.419</td> <td>19/32 (15)</td> </tr> </tbody> </table>	Collar Number	Collar Dim. "H"	599.419	19/32 (15)		
Collar Number	Collar Dim. "H"						
599.419	19/32 (15)						
Cylinder Length (Dim "A")	Cylinder Collar	Cylinder	Cylinder Mounting Screws				
Up to 1-9/16 (39)	599.419 (Std.)	6-Pin, Fixed Core 7-Pin, Fixed Core	60-7000-1235-048 (Std.)				
For other cylinder types, refer to 7000 Series Exit Device catalog for collar information.							

All dimensions are in inches (mm).

- B. Assemble cylinder, use components marked (\*). Pass Cylinder tailpiece through Cylinder Collar and Cylinder Housing slot in cam. Bolt Cylinder seated in Cylinder Collar recess. Do not over tighten screws.
- C. Check cylinder action. Cylinder key must freely rotate tailpiece into lock (cam pushing locking lever down) and unlock (shown above) positions. When locking lever is engaged, it depresses the trim spindle. The lever/knob/thumbturn is then disengaged from the spindle.
- D. Cut Cylinder tailpiece (Not trim tailpiece). Correct length is 1/16" to 3/16" (2mm to 5mm) beyond Cylinder Housing cam.
- E. Determine trim function.

**F08 & F11:** As shipped. Key locks/unlocks knob/lever/thumbturn.

**F09 & F12:** Field move Function screw to Cylinder Housing hole under cam tip. Key locks/unlocks knob/lever/thumbturn. Key removable ONLY in locked position.

## 4. Trim Assembly Instructions

A. Check cylinder components.

**NOTE:** Cylinders longer than 1-1/4" (32) will require collars. Refer to cylinder collar chart.

Cylinder Collar Chart	
Cylinder Length	Collar
1-1/8" (29)	None
1-1/4" (32)	None
1-1/2" (38)	1765.250**

\*\*Specify Finish

B. When required, cut cylinder tailpiece.

C. Assemble cylinder.

1. Insert cylinder housing prongs into matching notches of escutcheon.
2. Pass cylinder tailpiece through cylinder collar (when required) and slot in cylinder housing cam.
3. Fasten cylinder using (2) mounting screws.
4. Do not over tighten screws.

D. Check cylinder action.

1. Rotate cylinder tailpiece to cam the clutch lever down. This depresses the trim spindle assembly which disengages the trim spindle from the lever handle, putting the trim in a free-wheeling, locked mode.

E. To change trim function:

1. Rotate cam tip to down positions (locked mode).
2. Move function screw as shown in figure 4.

Figure 4

